

FluoroSeal Inc.

Specialty Valves



LINED VALVES

LINED PLUG VALVES

PRECISION CAST BODY, PLUG AND COVER

FluoroSeal® Lined Plug Valves use investment casting method for the major pressure holding components.

- All casting components traceable to mill test certificates
- Investment cast on all materials for sizes 1/2" – 10" (ANSI/ASME Class 150 lbs)
- Investment cast on all materials for sizes 1/2" – 6" (ANSI/ASME Class 300 lbs)
- Investment cast on all materials for sizes DN 15 – DN 150 (PN 16 – PN 40)



Lined Valve Section View

CORROSION PROTECTION

FluoroSeal® standard base model offers Carbon Steel body, plug and cover (ASTM A216 Gr. WCB, 1.0619). Even though FluoroSeal Inc. offers the low porosity PFA (Perfluoroalkoxy) as standard, all cast parts have an epoxy-based coating prior to lining for added protection from corrosion attack due to permeation.

LOCKED-IN LINER

Lined Plug Valves feature a virgin, unpigmented PFA lining applied by Transfer Molding and locked into castings by machined dove tail shaped grooves, and cast dovetail-shaped recesses in body castings and cast holes. This helps prevent liner collapse in vacuum conditions and blow out in high pressure conditions in conjunction with high temperatures.



Lined Plug Cutaway

The Transfer Molding method ensures equal distribution and consistency of liner throughout the entire surface of the lined components. FluoroSeal® Lined Plug Valves comply with the industry specifications (ASTM F1545) dictating the liners' uniform thickness across the entire valve and guarantee the absence of any weak section in the valve liner. Absence of pigmentation in the PFA renders all defects visible and testifies to FluoroSeal Inc.'s commitment of quality first. The use of virgin PFA reduces stress in the lining which could be caused by the use of regrind in its composition.

CAVITY-FREE DESIGN

By design, Plug Valves are cavity-free both in open and closed positions. This prevents the accumulation of particles between the plug and body and makes the valve ideal for corrosive slurry applications.

LARGE SEALING AREA

The interface between the tapered outer plug and the tapered inner body liner provides a 360° sealing area. This results in a tight shutoff. The seal is created due to compression between the plug and body, thus the valve is bidirectional and seals on both upstream and downstream sides simultaneously.



Dovetail Liner Section

IN-LINE ADJUSTMENT

FluoroSeal® Lined Plug Valves feature the state-of-the-art EZ-SEAL® (patent pending) adjustment mechanism, available on sizes 1/2" to 6" (DN 15 to DN 150). No special tooling is needed to adjust an EZ-SEAL®, and the latter allows effective maintenance planning and extended service life through simple visual diagnostic. As the valve is being adjusted throughout its operational span, the Min / Max gauge integrated into the EZ-SEAL® cover indicates its remaining service life. Regular visual readings of this gauge can assist plant managers and maintenance crews in scheduling of repairs and eventual line shut-downs before the wear on the valve reaches a critical point. The EZ-SEAL® system also includes an ISO bracket which enables direct mounting of actuation in a wide range of ISO patterns.

QUADRUPLE ATMOSPHERIC SEAL

Single point external adjusting bolt (patent pending) in the EZ-SEAL® cover ensures equilibrium to the compression of the stem and in-line seals by imparting a balanced force through a metal thrust cam inserted in the cover above the formed metal diaphragm. This system provides a definitive advantage over other adjustment methods available on the market by eliminating all side loading and related wear-and-tear on the liner.

The primary seal of the plug valve is between the plug and body liner. The additional sealing levels are an integrated delta ring and PTFE diaphragm completely encapsulated by a metal diaphragm. The delta ring and PTFE diaphragm have a double role of plug and stem seal. The specially formed metal diaphragm assists in encapsulation, acts as an antistatic device, and is a metal seal to atmosphere, in case of PTFE failure. The combined mechanism provides an excellent, quadruple seal to atmosphere and a bi-directional in-line seal adjustment.

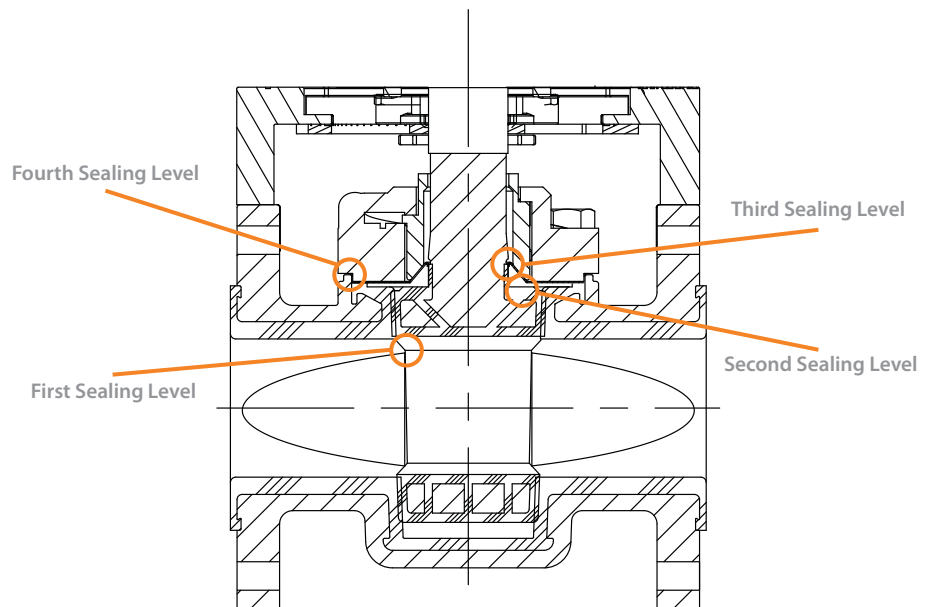

PLUG-ANSI-DIN-R001-2008

LINED PLUG VALVES

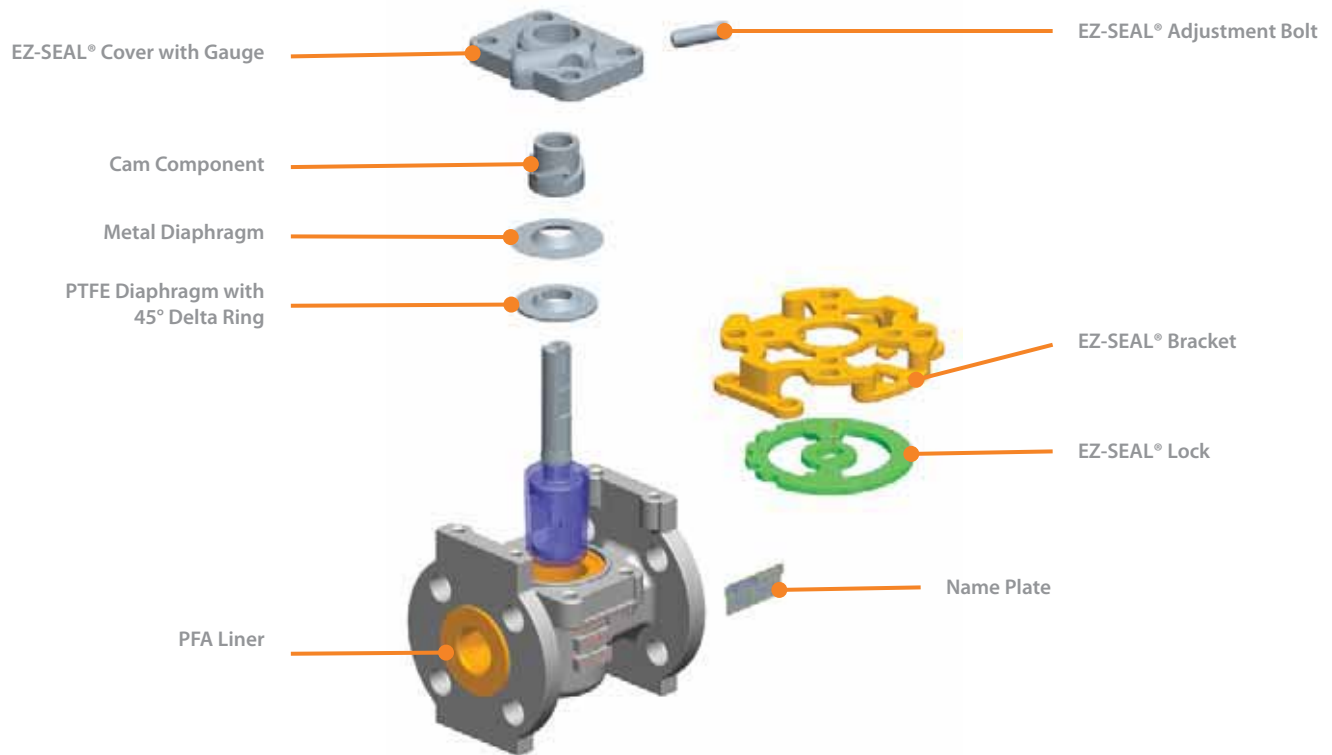

Lined Valve Exploded View

LINED ANSI/ASME CLASS 150 LBS

Flanged Ends

Wrench or Enclosed Gear Operated

Actuators Optional on All Sizes

Dimensions to ANSI B16.5 & B16.10

EG = Enclosed gear operated

N = Number of holes

Two (2) top holes in flanges are tapped with UNC threads. See Hole-UNC column

* Available upon request

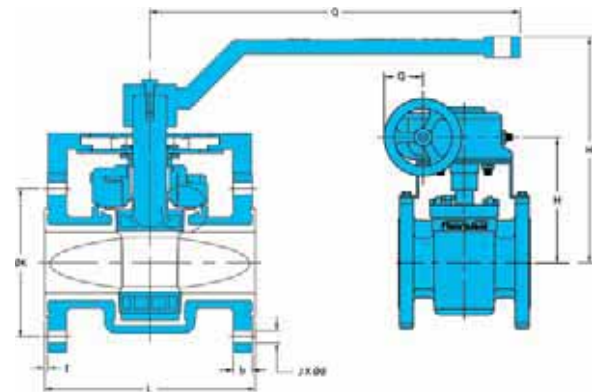

SIZE & PRODUCT DESCRIPTION	L		H		D		K		g		b		f		d		Q		N	Hole-UNC
	in	mm	in	mm	in	mm	in	mm	in	mm	in	mm	in	mm	in	mm	in	mm	#	
1" LR152F/W-WCB/PFA	5.00	127.00	5.57	141.48	4.25	108.00	3.13	79.50	2.00	50.80	0.49	12.45	0.098	2.50	0.63	16.00	8.27	210.00	4	-
1 1/2" LR152F/W-WCB/PFA	6.50	165.10	6.80	172.72	5.00	127.00	3.88	98.60	2.88	73.20	0.59	14.99	0.098	2.50	0.63	16.00	10.33	262.40	4	-
2" LR152F/W-WCB/PFA	7.00	177.80	7.54	191.52	6.00	152.40	4.75	120.70	3.63	92.00	0.63	16.00	0.098	2.50	0.75	19.00	12.40	315.00	4	-
3" LR152F/W-WCB/PFA	8.00	203.20	8.10	205.74	7.50	190.50	6.00	152.40	5.00	127.00	0.79	20.07	0.098	2.50	0.75	19.00	12.40	315.00	4	-
4" LR152F/W-WCB/PFA	9.00	228.60	9.56	242.82	9.00	228.60	7.50	190.50	6.19	157.20	0.94	23.90	0.098	2.50	0.75	19.00	24.30	617.20	8	-
4" LR152F/EG-WCB/PFA	9.00	228.60	11.80	299.72	9.00	228.60	7.50	190.50	6.19	157.20	0.94	23.90	0.098	2.50	0.75	19.00	7.25	184.00	8	-
6" LR152F/EG-WCB/PFA	10.50	266.70	14.00	355.60	11.00	279.40	9.50	241.30	8.50	215.90	1.00	25.40	0.098	2.50	0.88	22.40	7.25	184.00	8	-
8" LR152F/EG-WCB/PFA*	11.50	292.10	13.00	330.20	13.50	342.90	11.75	298.50	10.63	269.80	1.13	28.70	0.098	2.50	0.88	22.40	9.75	248.00	8	3/4"-10
10" LR152F/EG-WCB/PFA*	13.00	330.20	14.94	379.48	16.00	406.40	14.25	362.00	12.75	323.90	1.19	30.20	0.098	2.50	1.00	25.40	9.75	248.00	12	7/8"-9
12" LR152F/EG-WCB/PFA*	14.00	355.60	15.69	398.53	19.00	482.60	17.00	431.80	15.00	381.00	1.25	31.80	0.098	2.50	1.00	25.40	13.75	349.25	12	7/8"-9
14" LR152F/EG-WCB/PFA*	15.00	381.00	-	-	21.00	533.40	18.75	476.30	16.25	412.80	1.38	35.10	0.098	2.50	1.12	28.40	-	-	12	1"-8

PLUG-ANSI-DIN-R001-2008